



PROJECT 2039
20.12.2023

VO LUNTEREN WOONERF EDESEWEG

VOORONTWERP ERFBEBOUWING



INHOUDSOPGAVE

03	Luchtfoto		44	Impressie
04	Foto's bestaande locatie		45	Impressie
05	Te slopen bebouwing		46	Impressie
06	Situatie		47	Impressie
07	Schuurwoningen		48	Impressie
08	Situatie schuurwoningen	1:500	49	Impressie
09	Plattegronden en doorsnede Schuurwoningen	1:200	50	Impressie
10	Gevels schuurwoningen	1:200		
12	Impressie Schuurwoningen			
13	Tweekapper			
14	Situatie Tweekapper	1:500		
15	Plattegronden en doorsnede tweekapper	1:200		
16	Gevels Tweekapper	1:200		
17	Impressie tweekapper Variant			
18	Seniorenwoningen			
19	Situatie Seniorenwoningen	1:500		
20	Plattegronden en doorsnede seniorenwoningen	1:100		
21	Gevels Seniorenwoningen	1:200		
22	Impressie Seniorenwoningen			
23	Vrijstaand woonhuis			
24	Situatie Vrijstaande woning	1:500		
26	Gevels vrijstaande woning	1:200		
27	Impressie vrijstaand woonhuis			
28	Impressie vrijstaand woonhuis			
29	Impressie vrijstaand woonhuis			
30	Gemeenschappelijk gebouw			
31	Situatie Gemeenschappelijk gebouw	1:500		
32	Plattegronden en doorsnede gemeenschappelijk gebouw	1:100		
33	Gevels Gemeenschappelijke gebouw	1:200		
34	Variant Gemeenschappelijk gebouw			
35	Totaalbeelden erfbebouwing			
36	Vogelvlucht			
37	Vogelvlucht			
38	Vogelvlucht			
39	Vogelvlucht			
40	Impressie			
41	Impressie			
42	Impressie			
43	Impressie			

DATUM 20.12.2023
PROJECT 2039 - Lunteren - Woonerf Edeseweg

ARCHITECT
TVA architecten
Betekamp 11, 6712 EG Ede
0318 619 629 secretariaat@tva-architecten.nl

OPDRACHTGEVER
Bouwbedrijf Kreeft
Heestereng, Maxwellstraat 49 D, 6716 BX Ede
info@bouwbedrijfkreeft.nl







Hoofdgebouw



Hoofdgebouw achterzijde



Daken landschap



Kapschuur



Erf-schuren

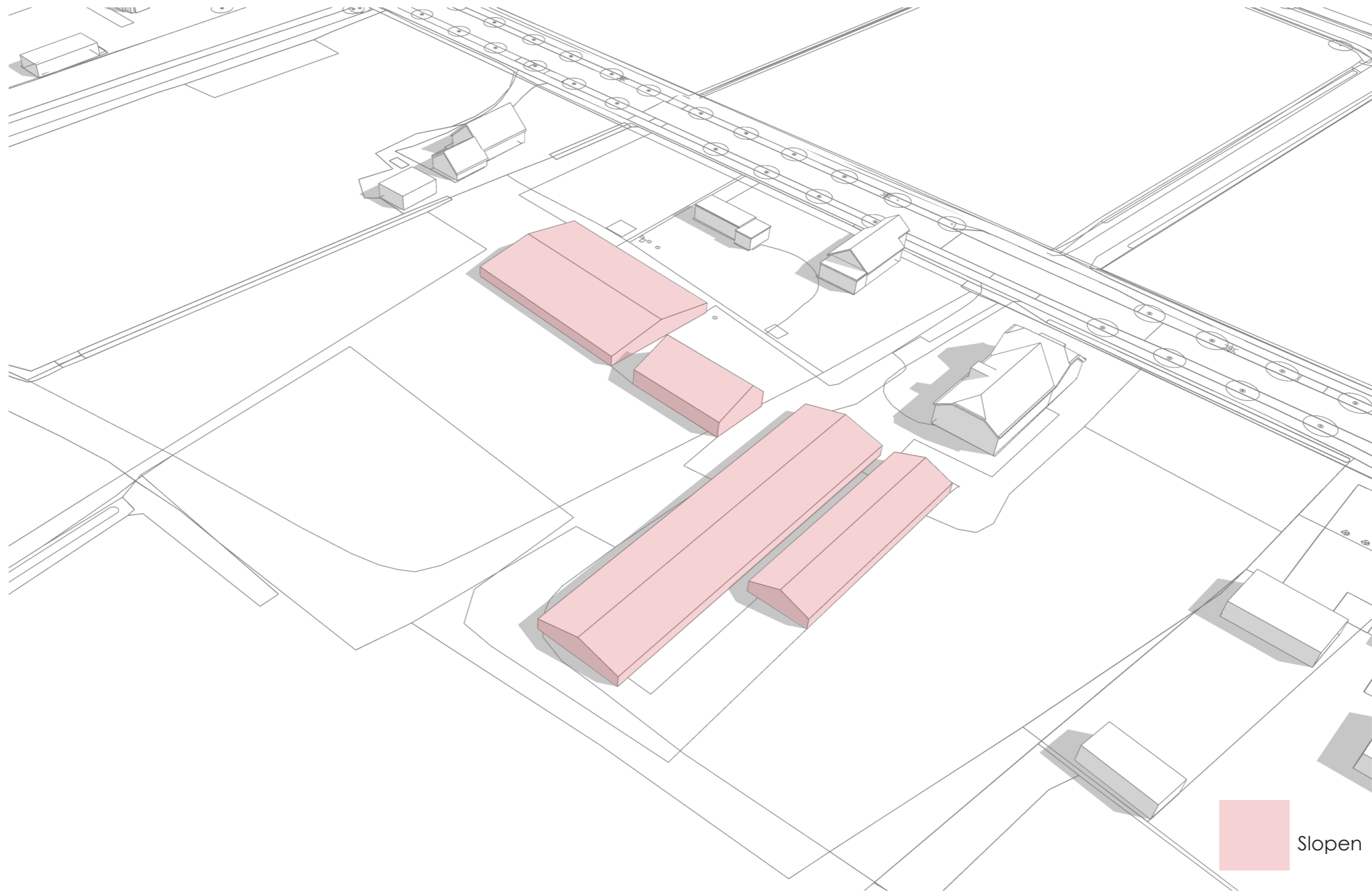

TE SLOPEN BEBOUWING



Omschrijving		parkeernorm	parkeren ben.	parkeren aanw.
2x ouderenwoning type 1a (onder NHG)	BVO 100-120m2	1.7	3.7	
2x ouderenwoning type 1b	BVO 100-120m2	1.7	3.7	
2x grondgebonden won. type 2a	BVO >120m2	2.0	4.0	
3x grondgebonden won. type 2b (onder NHG)	BVO >120m2	2.0	6	
2x grondgebonden won. type 2c (onder NHG)	BVO >120m2	2.0	4.0	
1x tweekapper type 3	BVO >120m2	2.0	4.0	
1x vrijstaande woning type 4	BVO >160m2	2.1	2.1	
1x Boerderij		1,8	1,8	
15 totaal			29.3pp	31.4pp

Bij deze berekening is uitgegaan van de nieuwe parkeernorm van de gemeente Ede

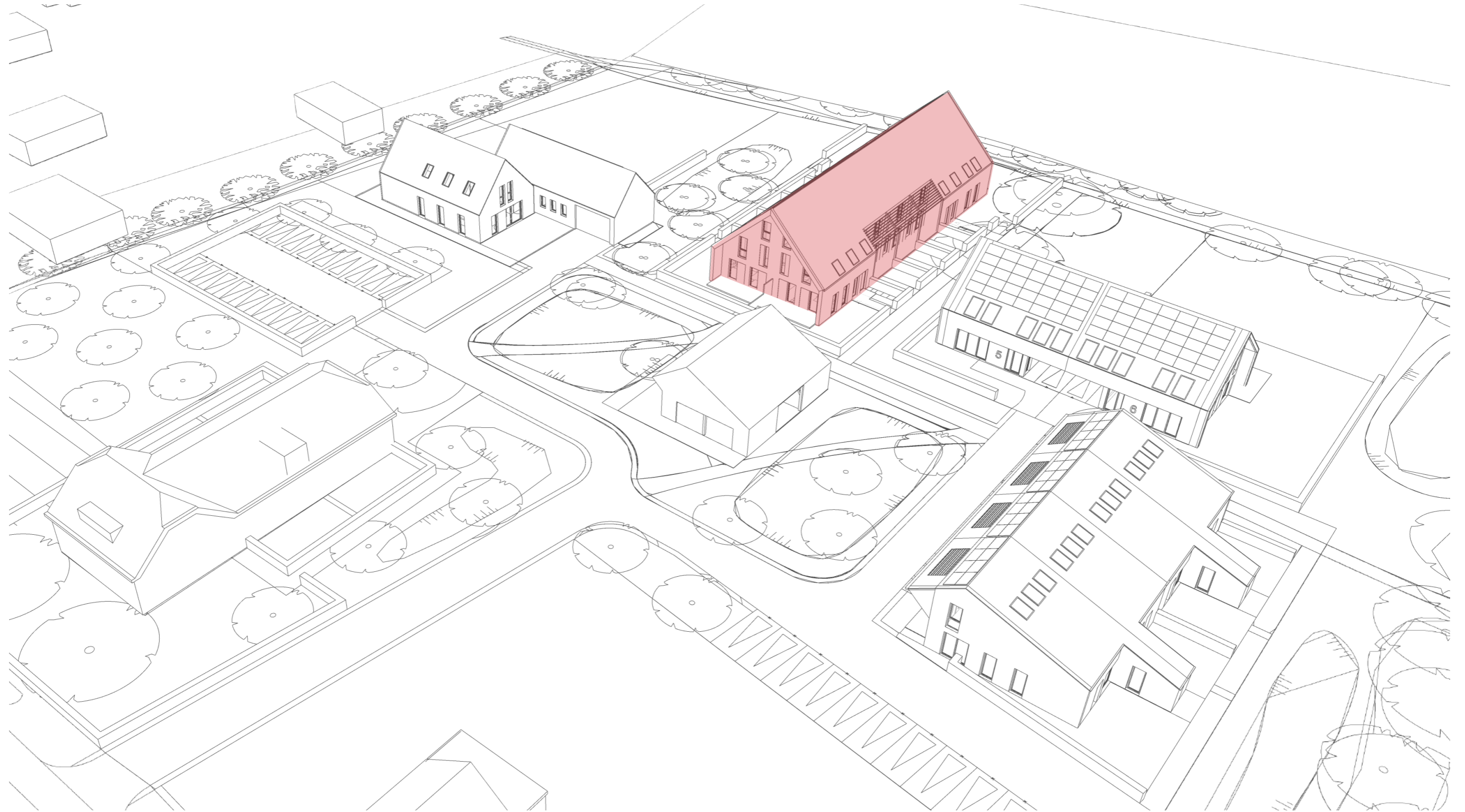



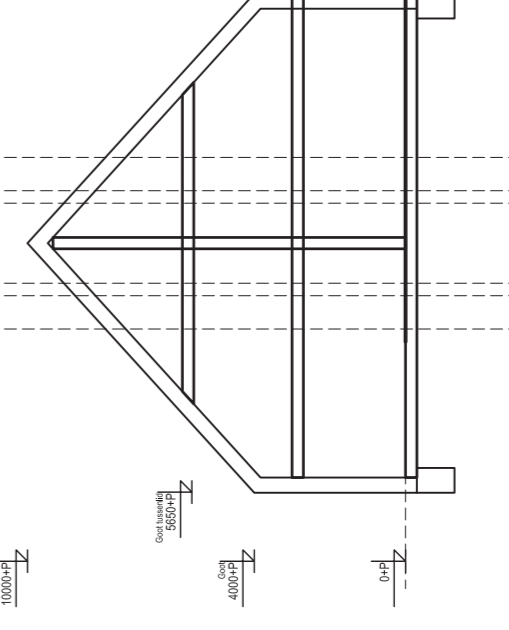
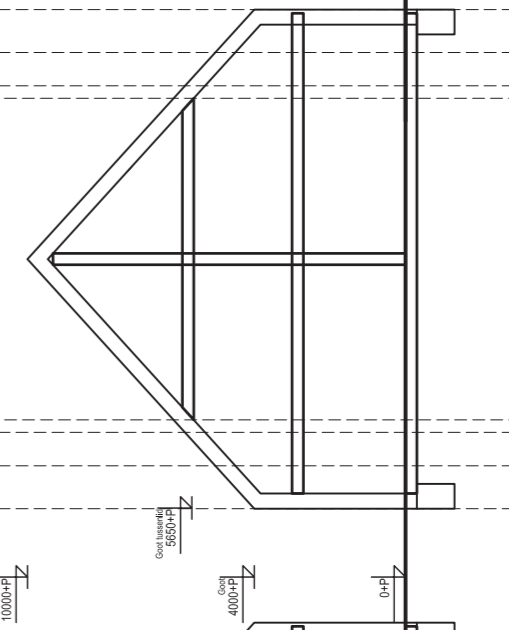
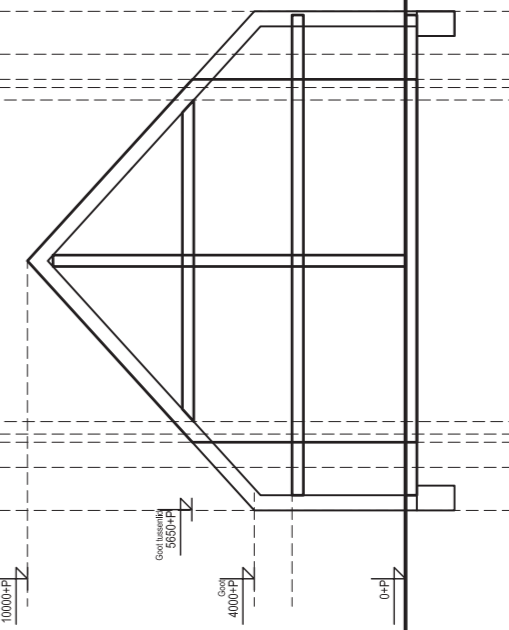
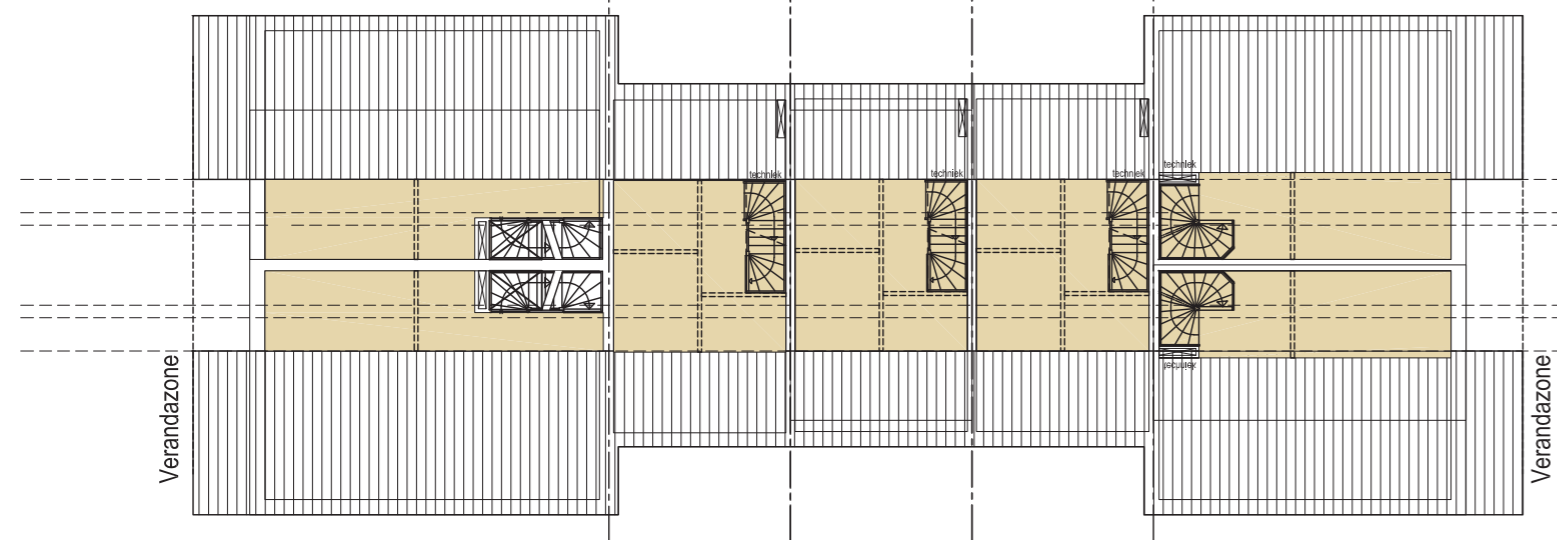
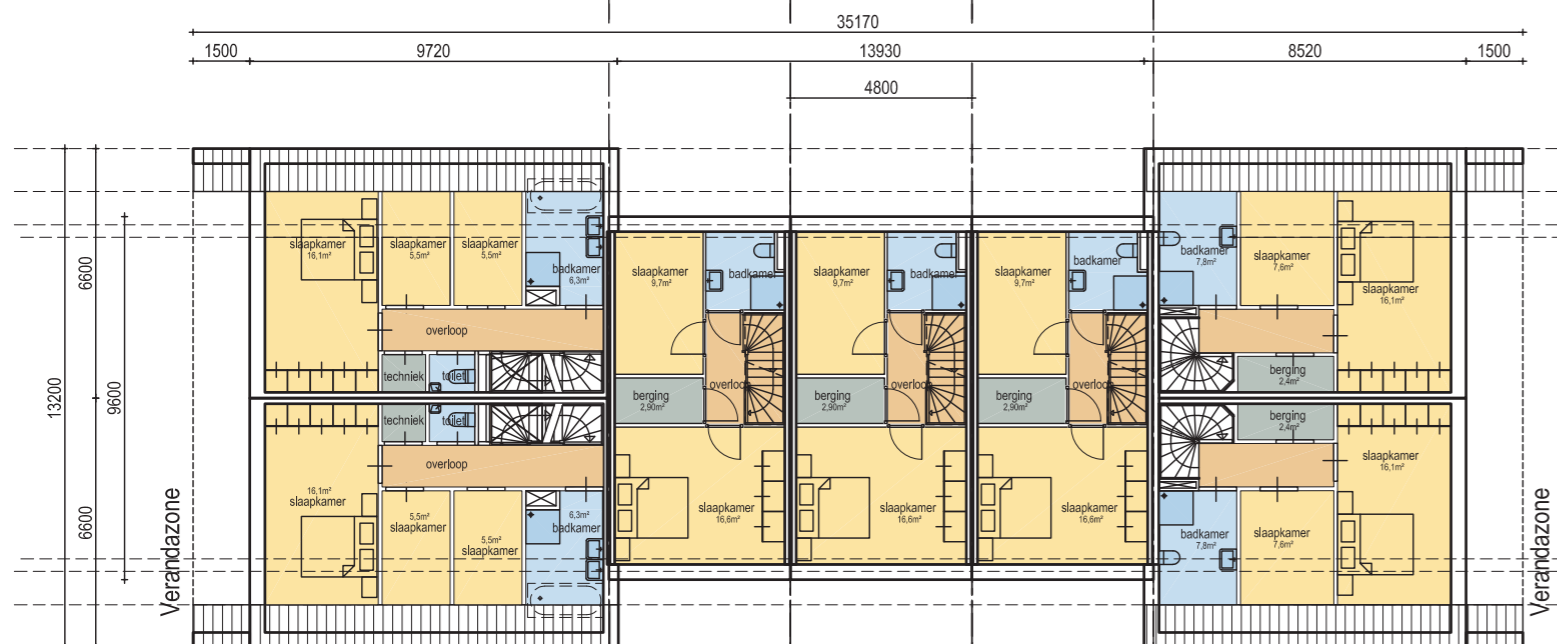
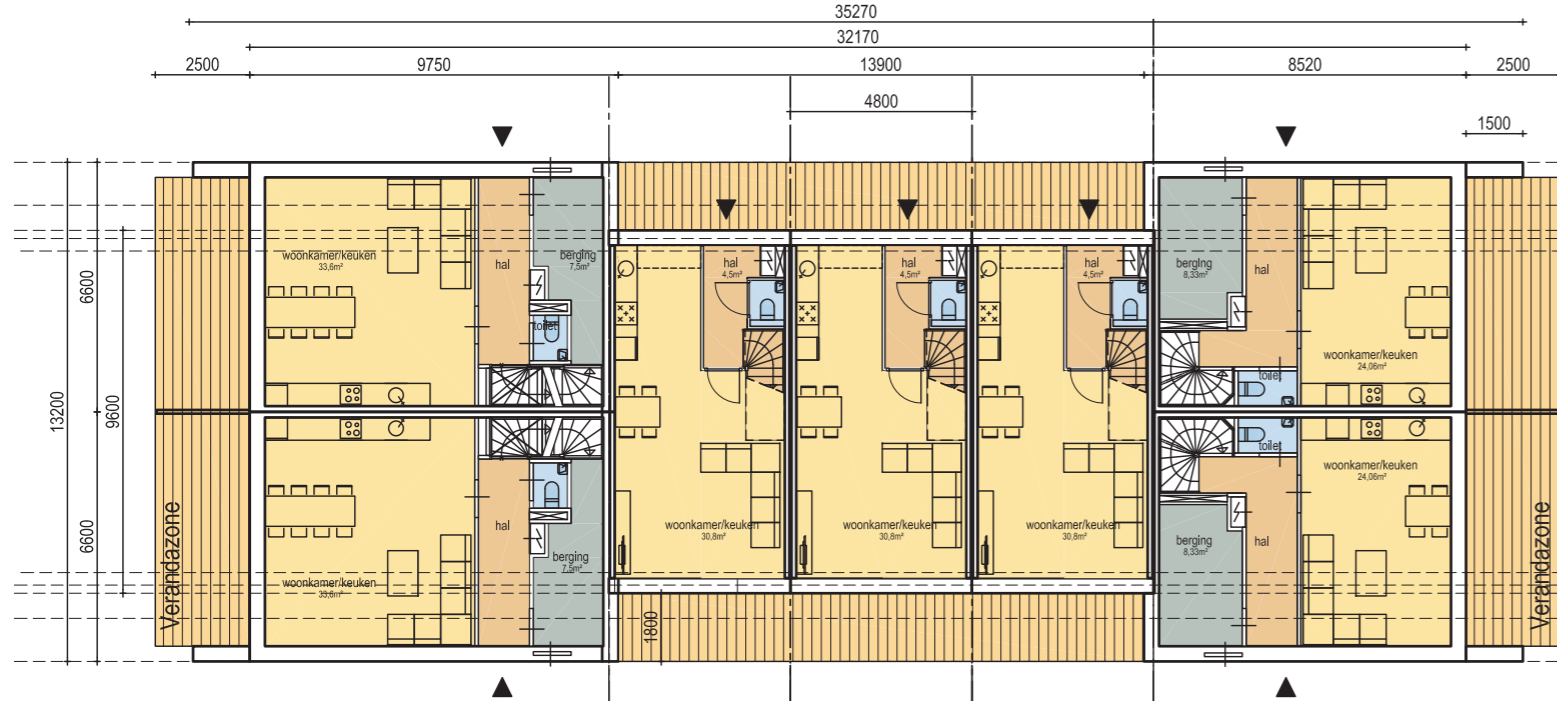





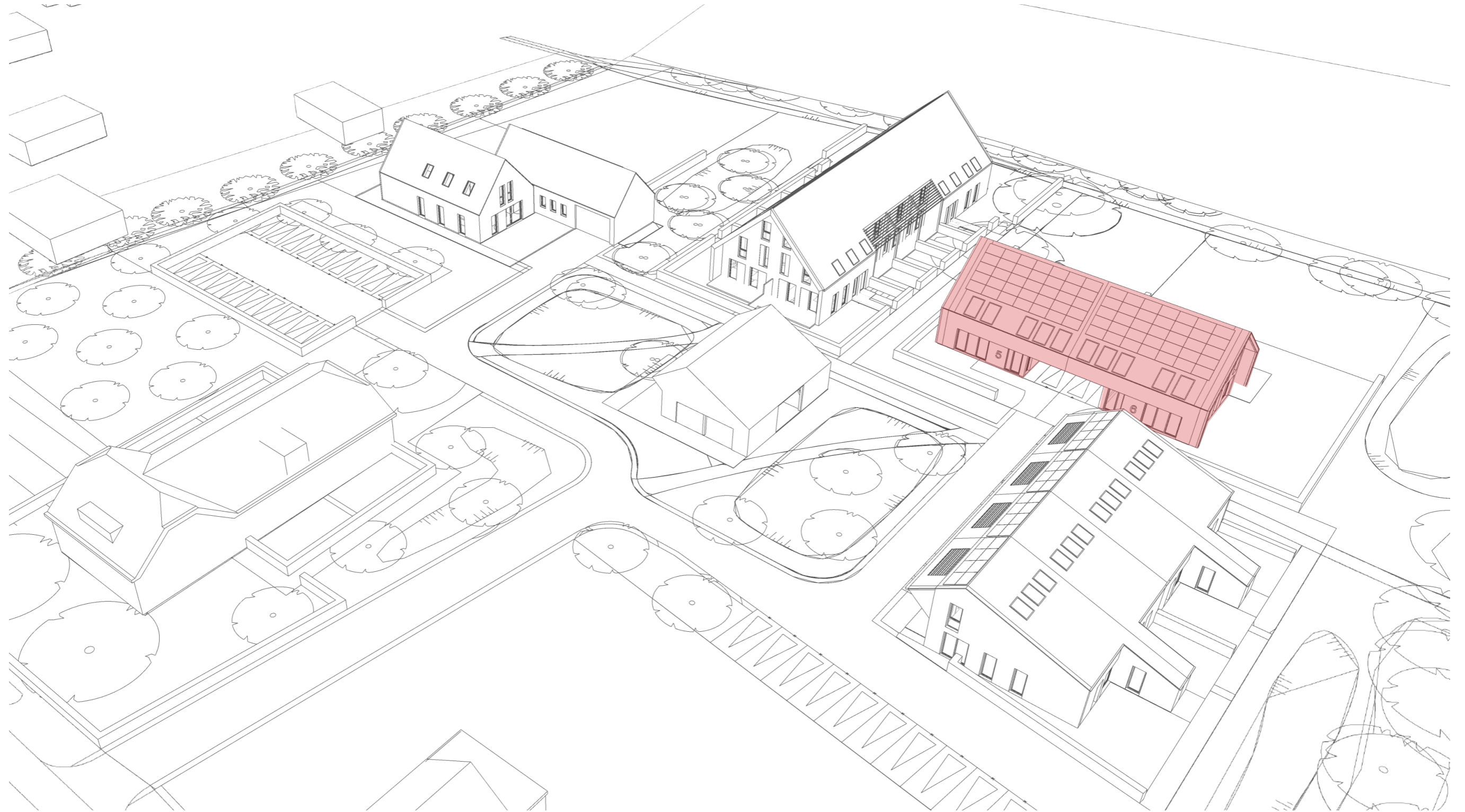



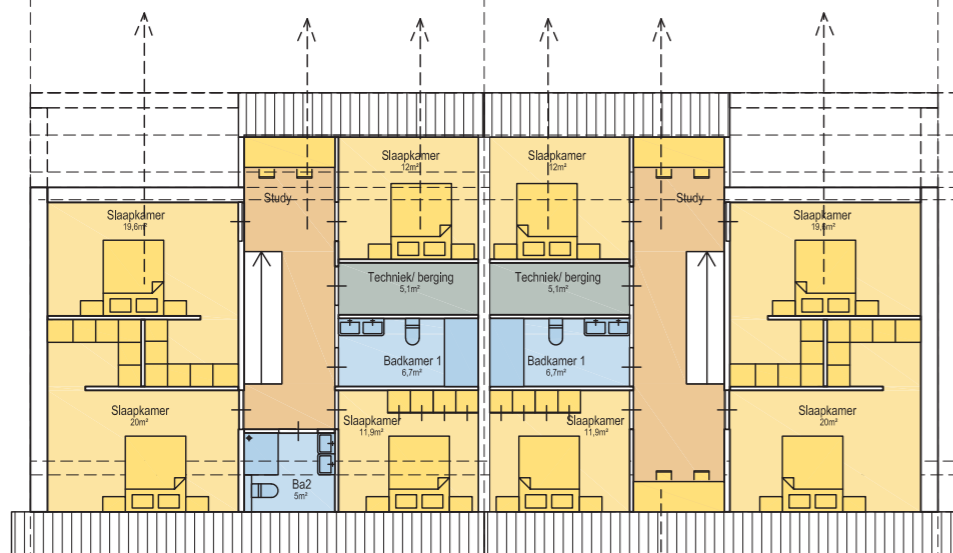

1e Verdieping

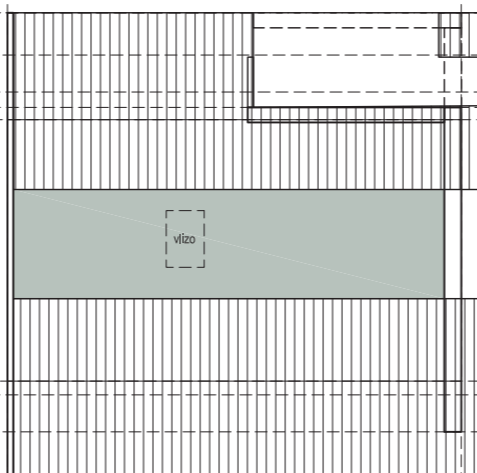

Zolder

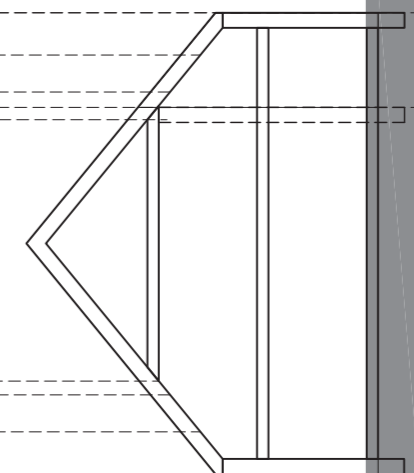

9000:1
1:1
4000:1
1:1

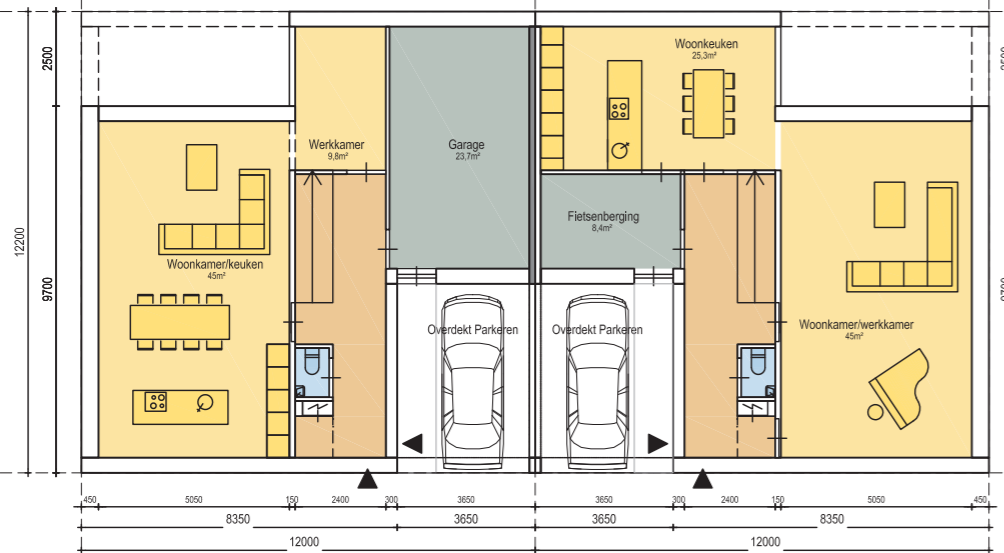

Begane grond

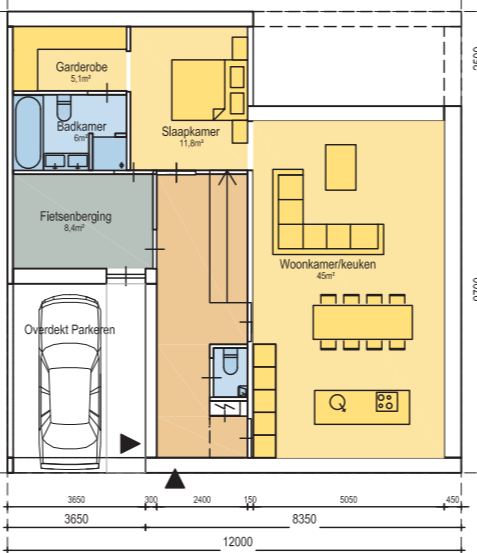

Alternatief begane grond

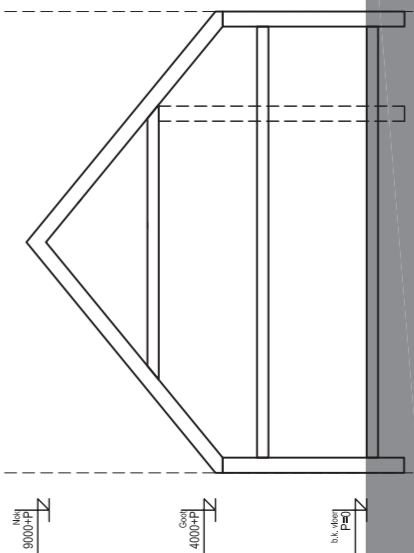

9000:1
4000:1
1:1

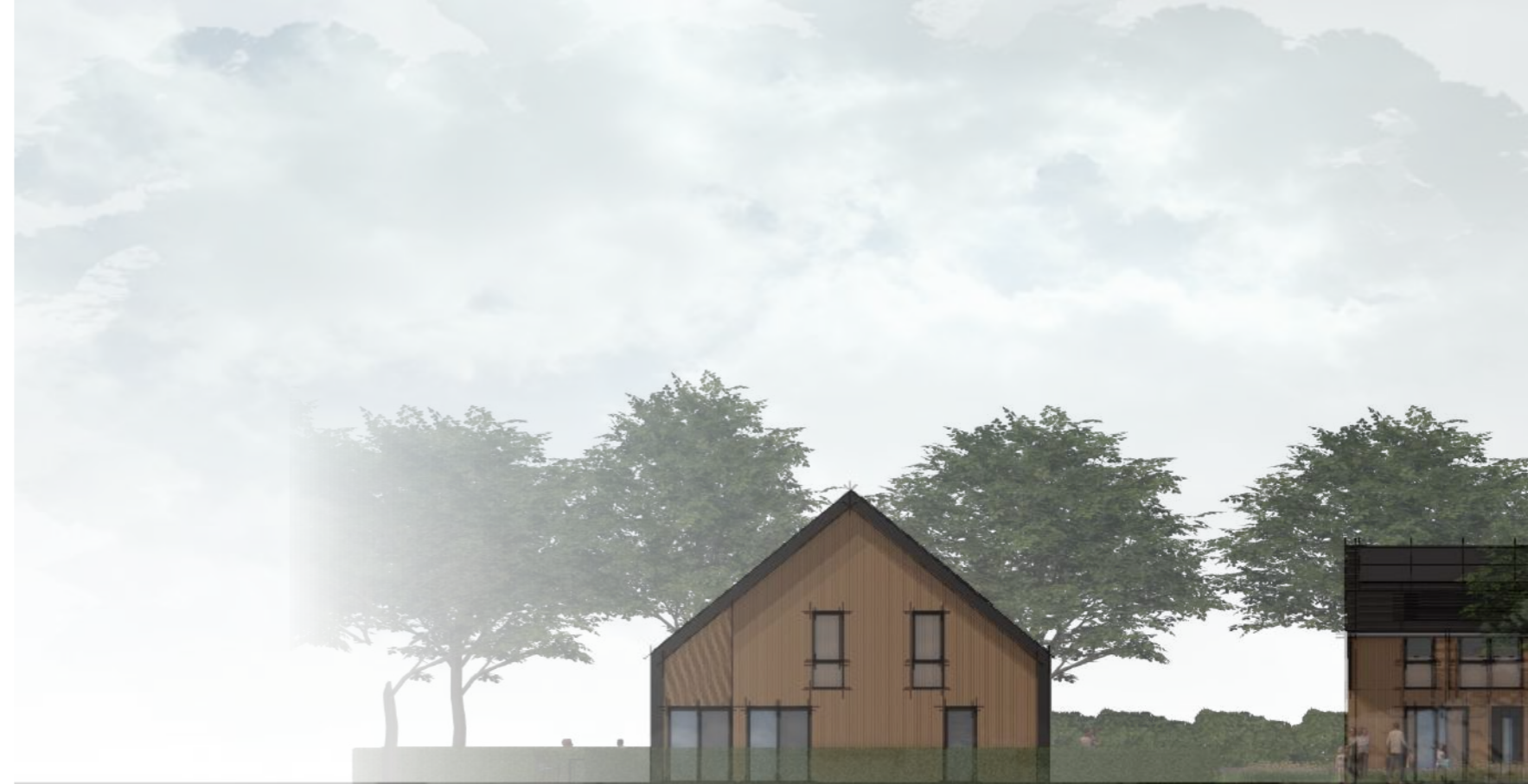

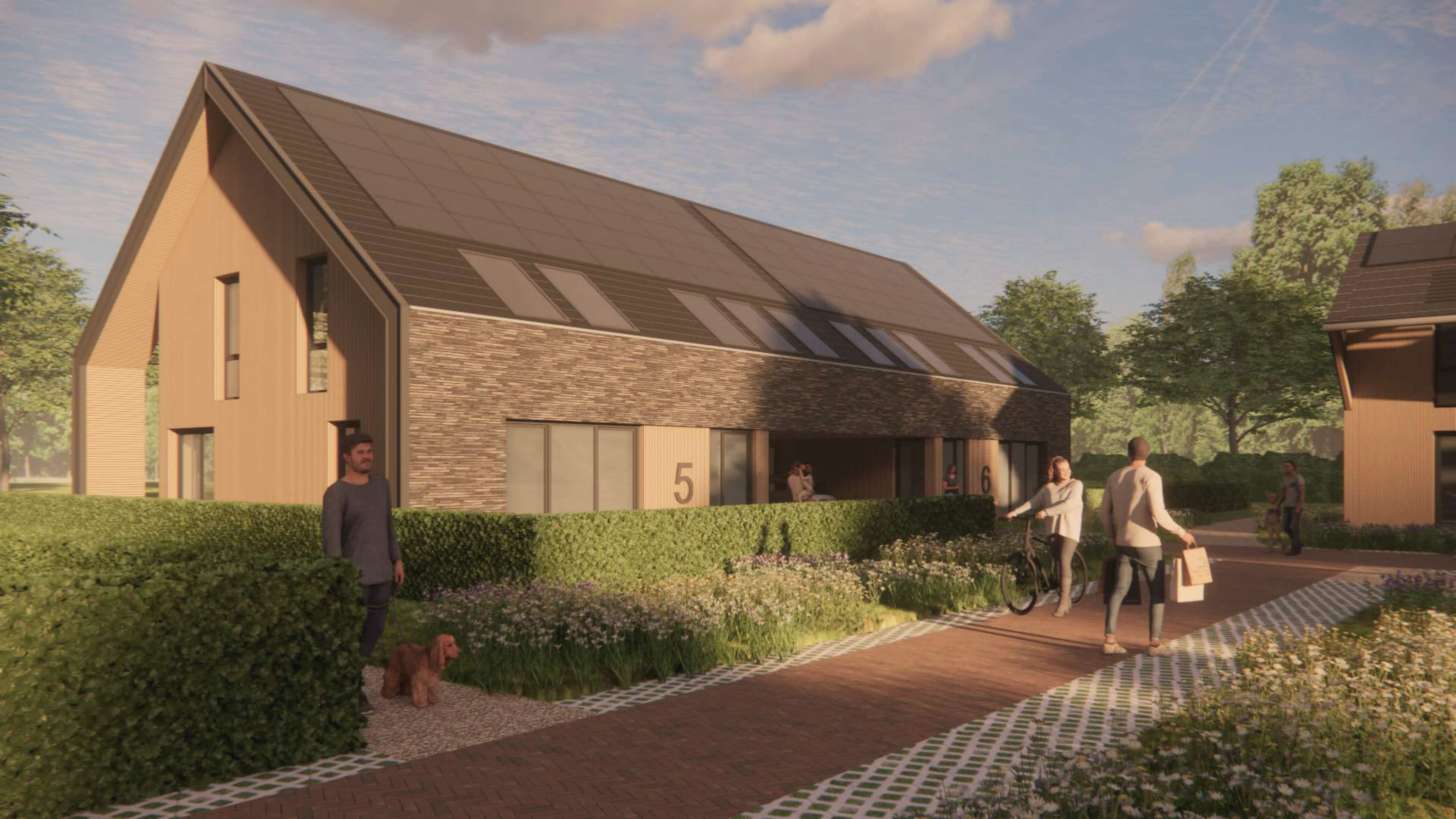

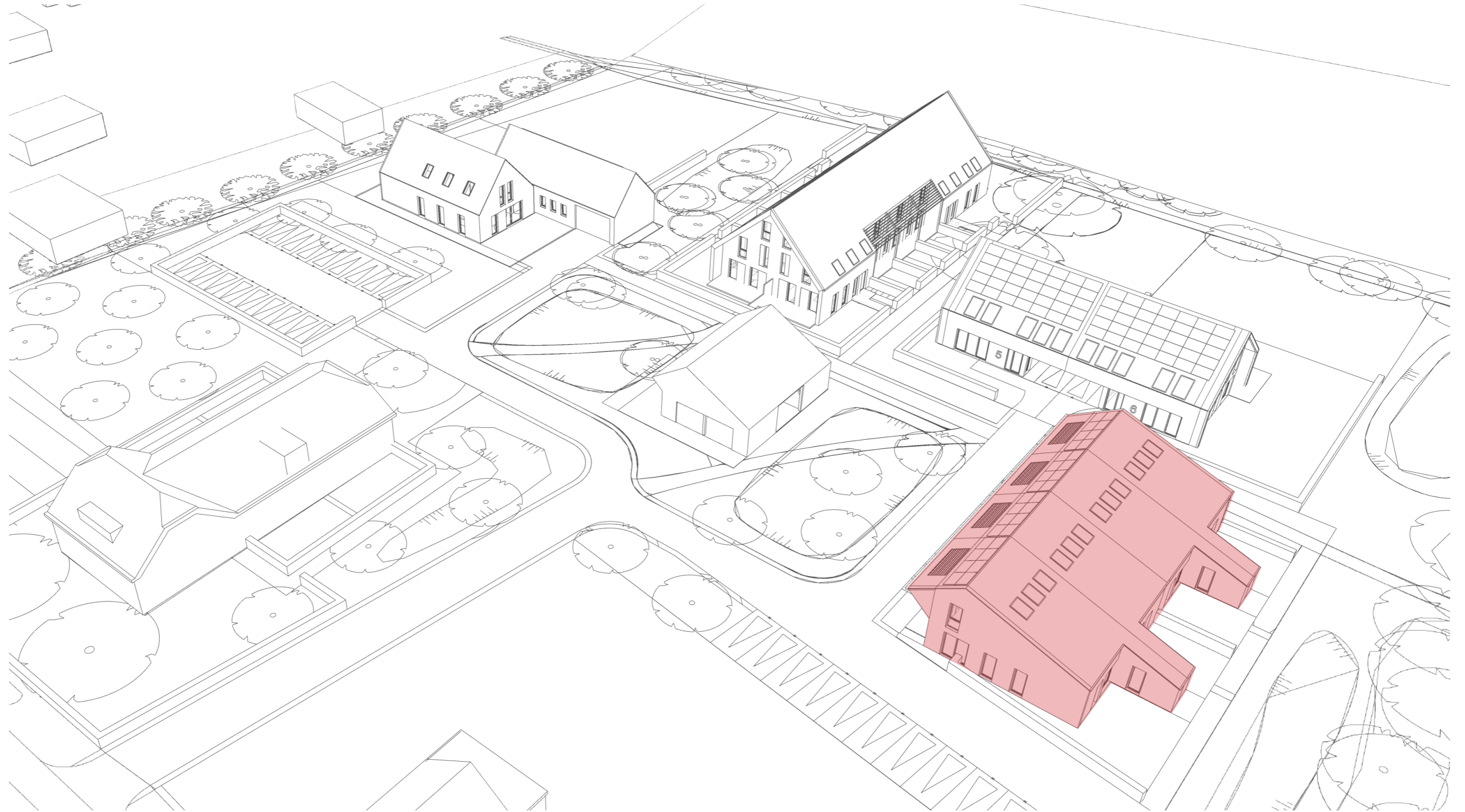



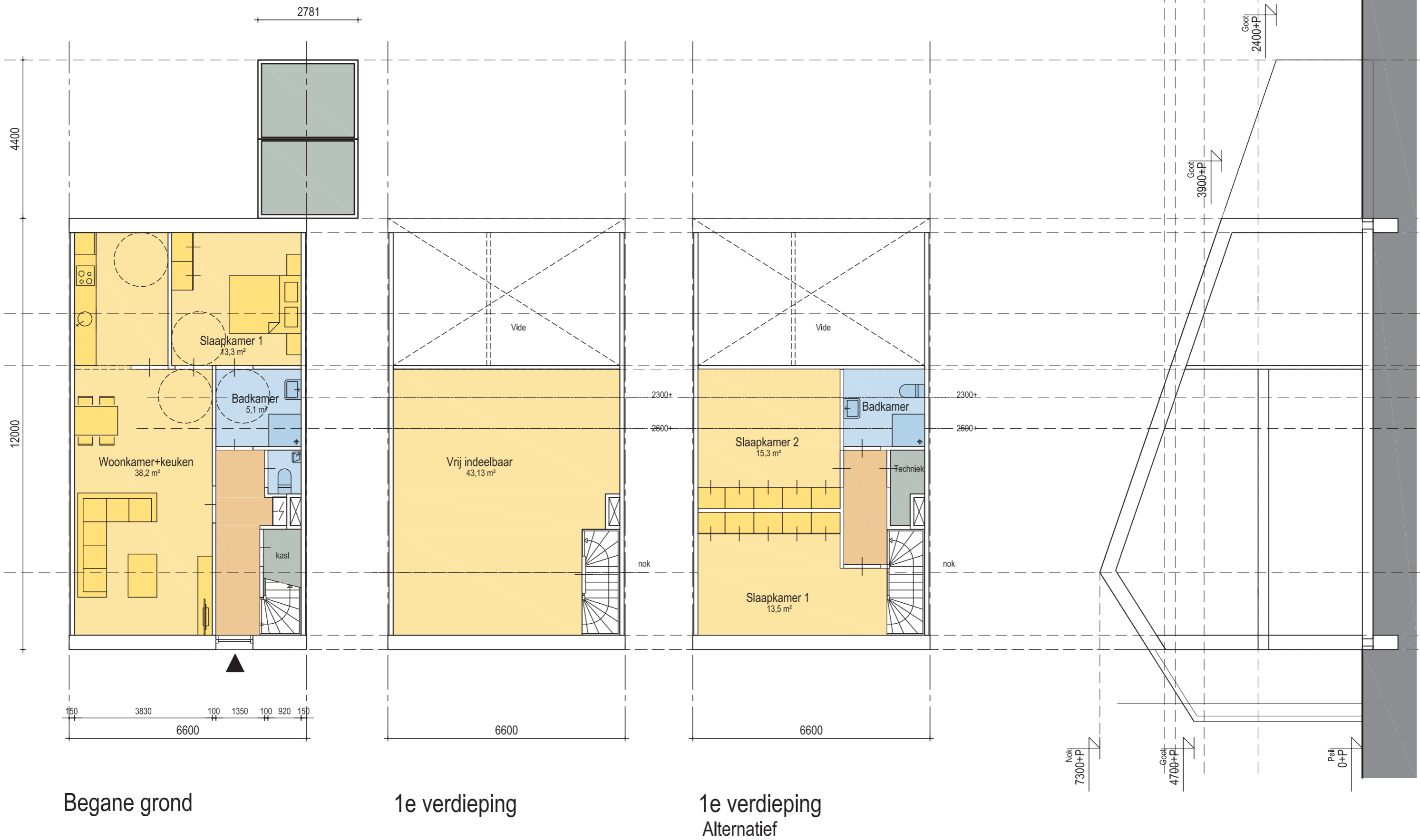





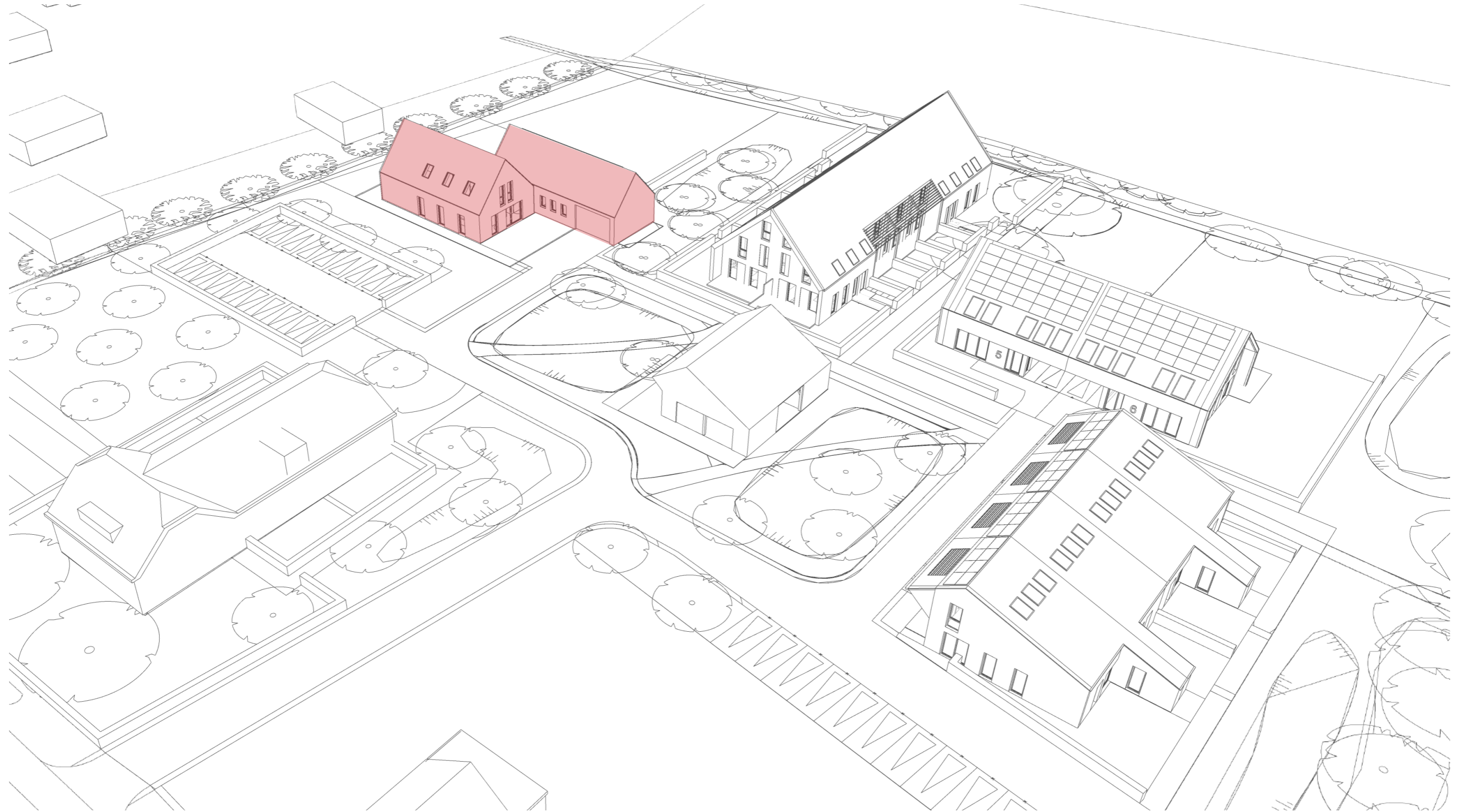











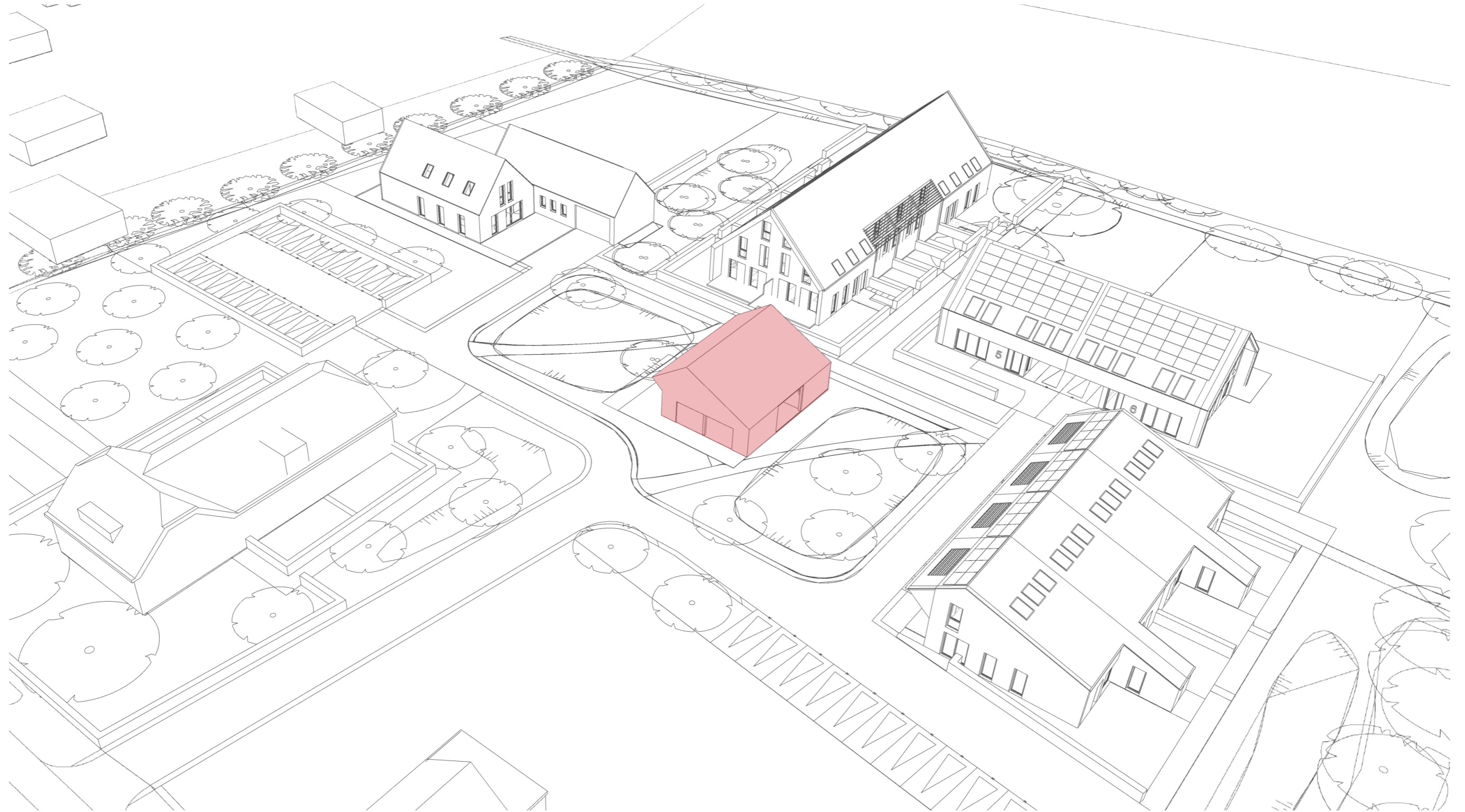



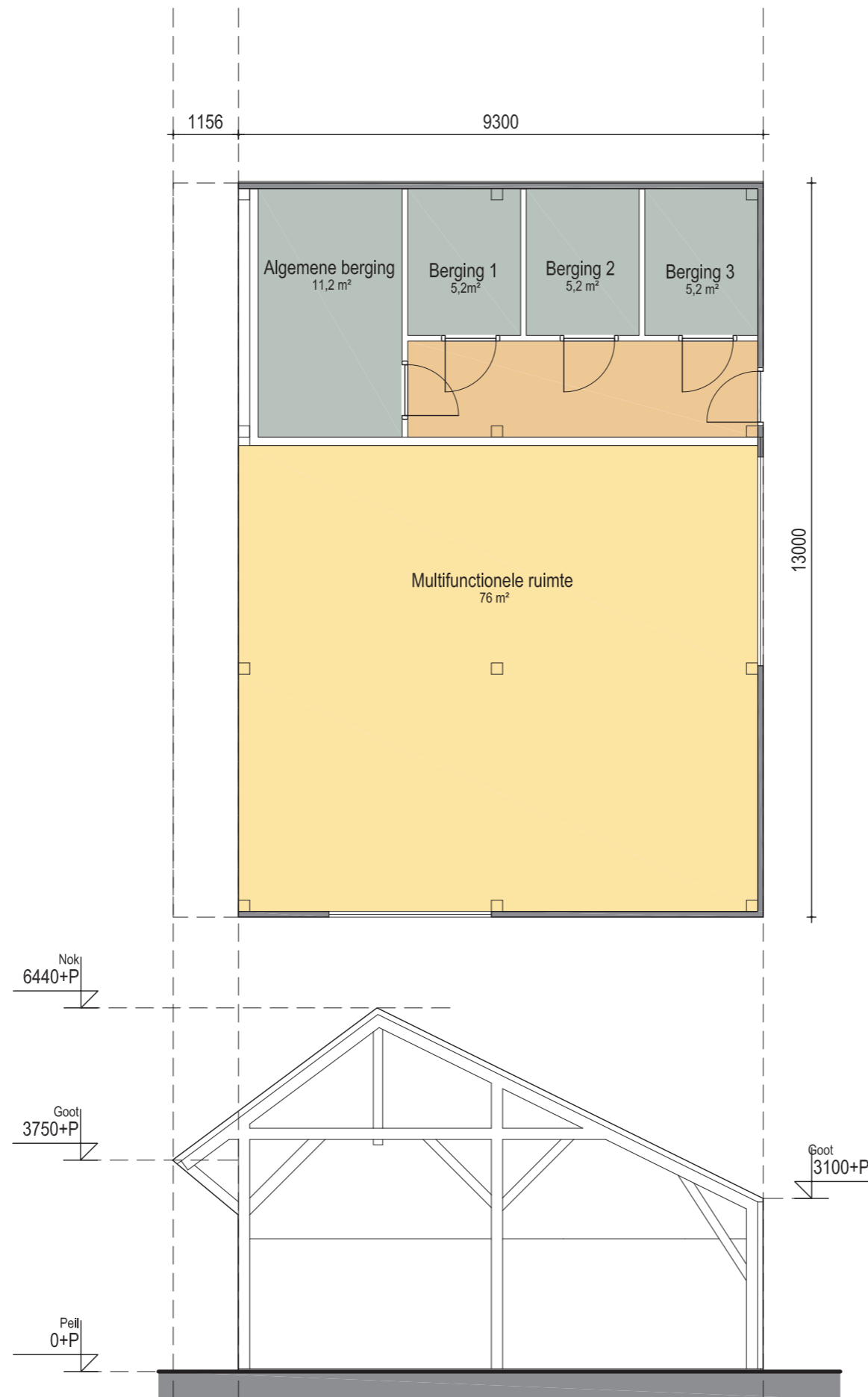

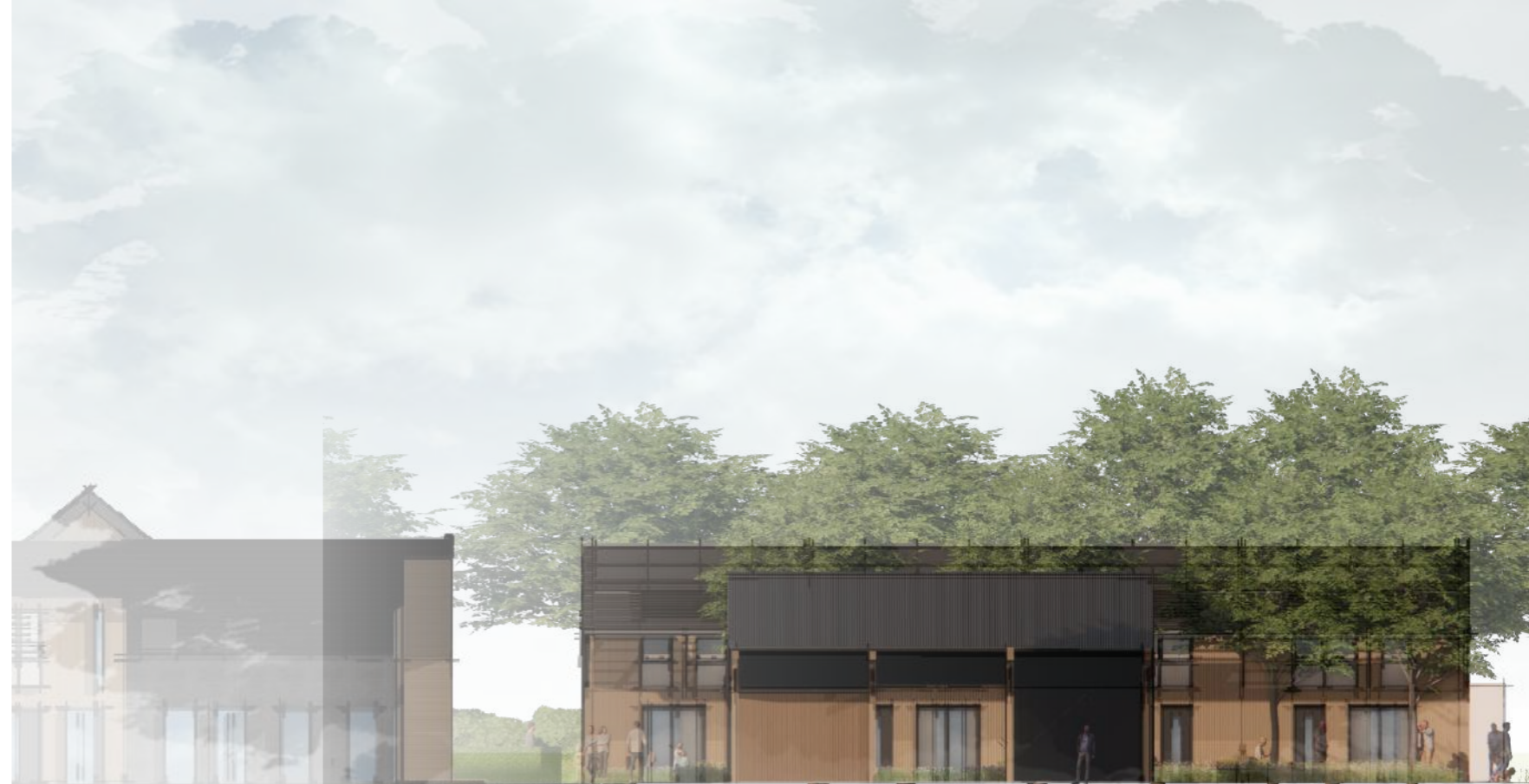



TOTAALBEELDEN ERFBEBOUWING

























